

Glance

40010576-0951



ENG

Installation guide

ENG

 **faber**

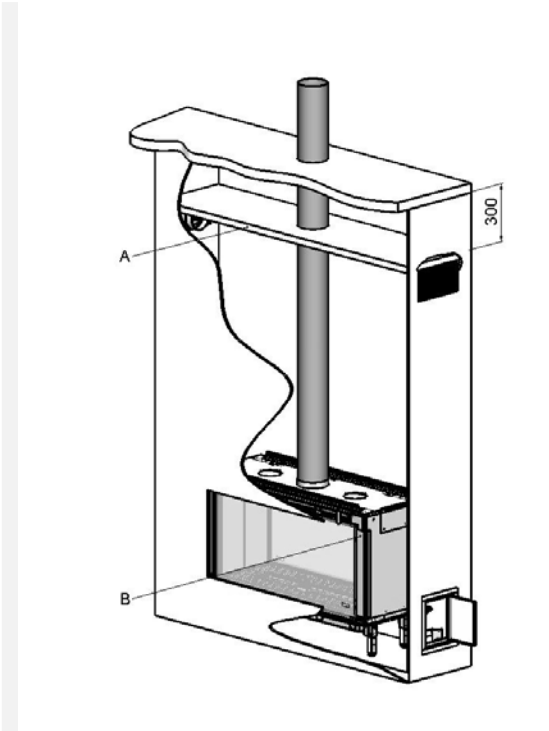

1.1

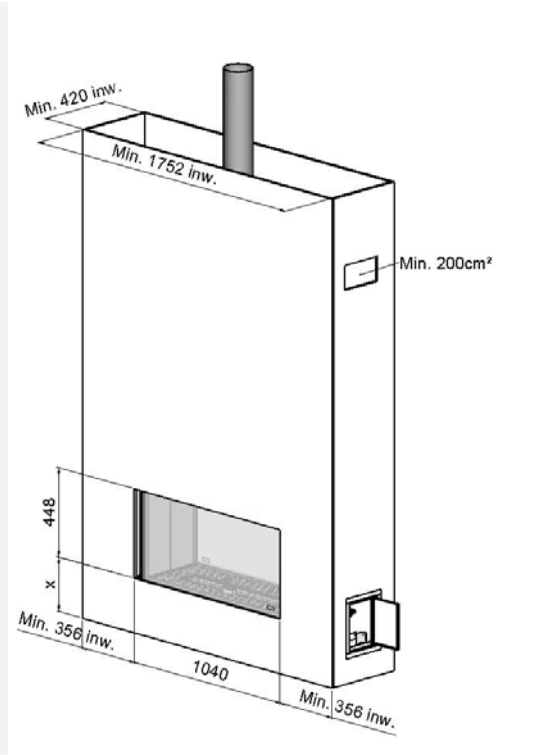

1.2

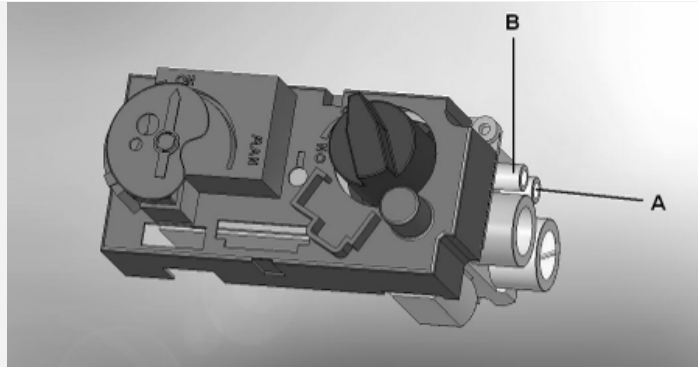

1.3

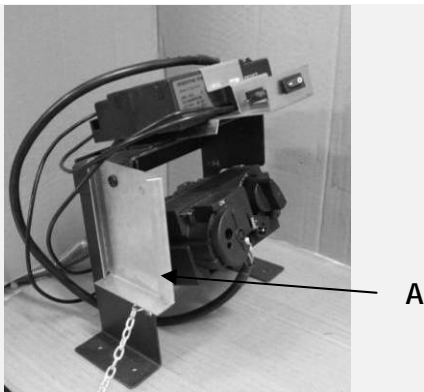

1.4



1.5

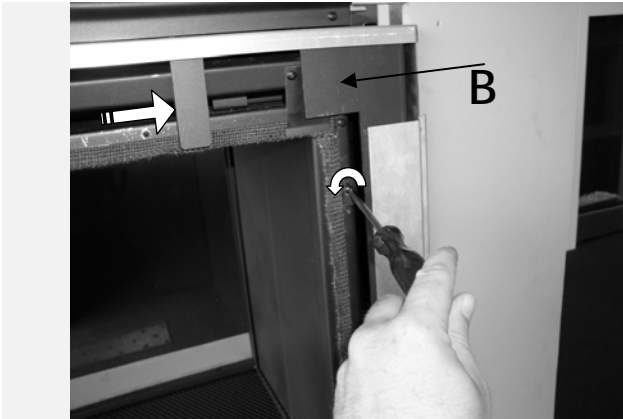

2.1



2.2

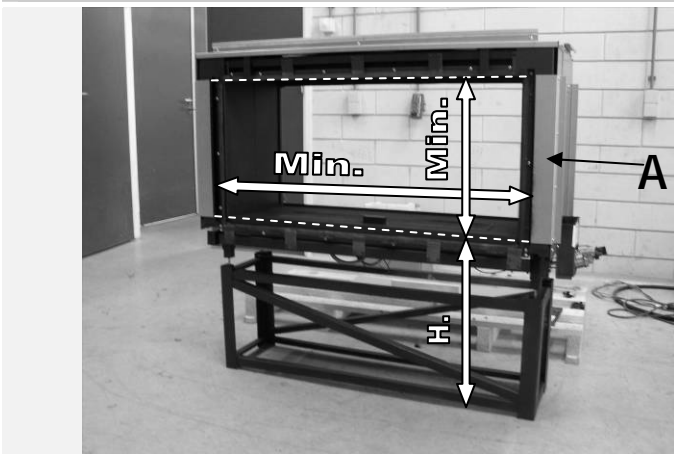

2.3



2.4

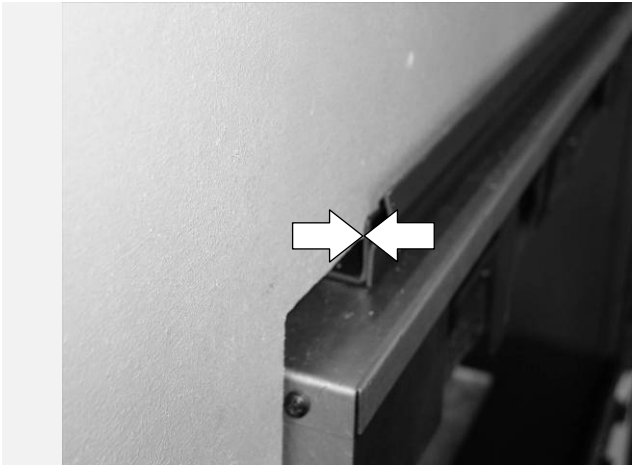

2.5

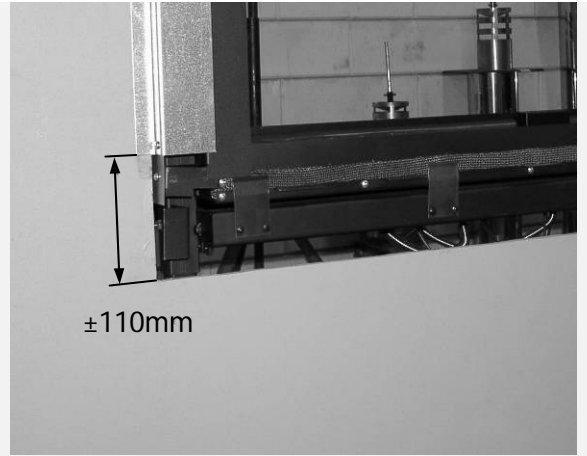

2.6

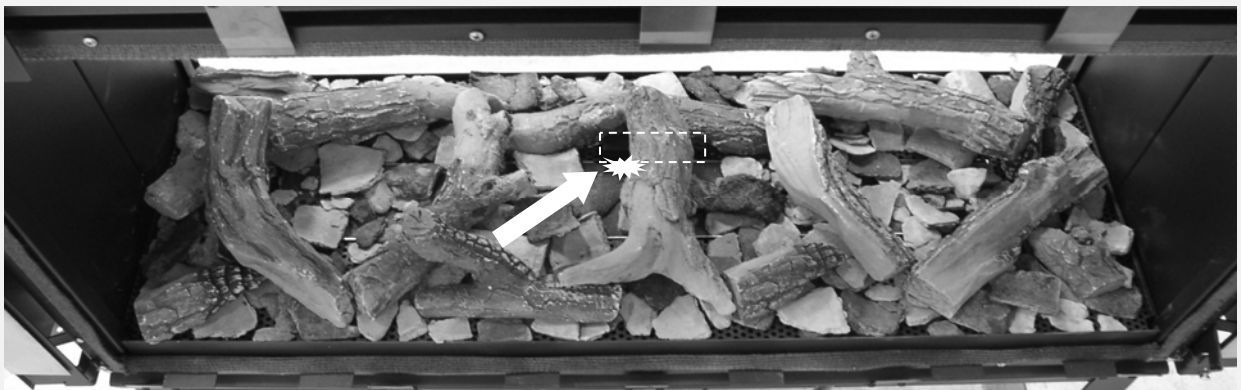

3.1

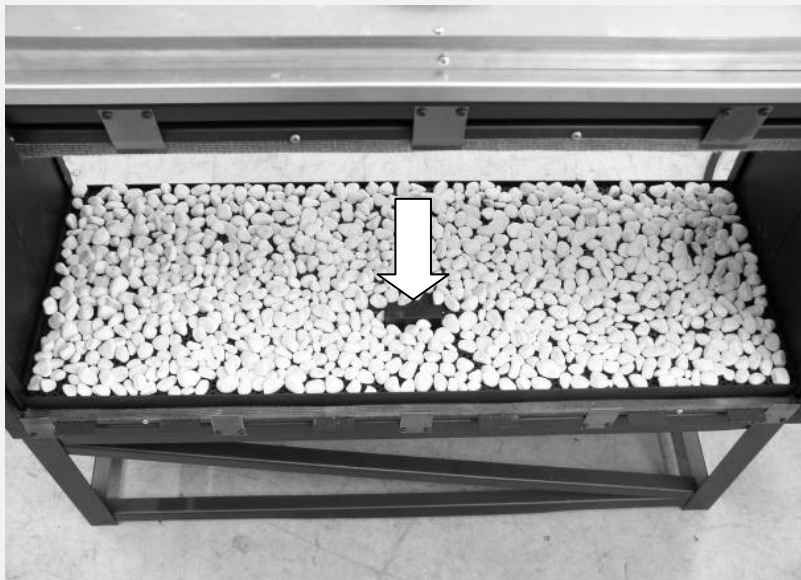

3.2



Inhoudsopgave

1	Introduction	6
2	Safety instructions.....	6
3	Installation requirements	7
3.1	The fire	7
3.2	False Chimney breast	7
3.3	Requirements flue system and outlets.....	7
3.4	terminals	8
3.5	Existing chimney	8
4	Preparation and Installation instructions	9
4.1	Gas connection	9
4.2	Electric connection	9
4.3	Preparation of the appliance.....	9
4.4	Placing the appliance.....	9
4.5	Mounting the smoke emission outlet materials	10
4.6	Building a chimney breast.	10
4.7	Chimney breast.....	10
4.8	Glance Frameless	11
4.9	Glance Framed	11
5	removing the glass.....	11
6	Placing the decorative material.....	12
6.1	Imitation logs	12
6.2	Pebbles	12
7	Checking the installation.....	13
7.1	Checking the ignition of the pilot burner, main burner.....	13
7.2	Checking for gas leakage.....	13
7.3	Checking the burner pressure and the pre-pressure	13
7.4	Checking the flame picture.....	14
8	Instructing the client.....	14
9	Annual maintenance	15
9.1	Service and cleaning:	15
9.2	Replace:	15
9.3	Cleaning the glass.....	15
10	Conversion to a different type of gas (e.g. propane)	15
11	Calculation of flue system	16
11.1	Points of particular interest:	16



11.2	Sample computations.....	17
12	Table	18
13	Technical data.....	19
14	Dimension of the appliance	20
15	Dimension of the appliance with frame	21
16	Ventilation Grills	22
17	Dimension Service Hatch.....	23



1 Introduction

The appliance can only be installed by a competent person in accordance with the Gas Safety. We urgently advise you to read this installation manual properly.

This appliance complies with the guidelines for European gas appliances (Gas Appliances Directive) and bears the CE mark.

2 Safety instructions.

- The appliance should be placed, connected and annually checked in accordance with these installation instructions and valid national and local Gas Safety (Installation and Use) Regulations .
- Check whether the data on the registration plate are in agreement with the local type of domestic gas and pressure.
- The fitter is not permitted to change these adjustments or the construction of the appliance!
- Do not place any additional imitation logs or glowing coals on the burner or in the combustion chamber.
- The appliance has been designed for ambience and heating purposes. This means that all surfaces of the appliance , including the glass, can become very hot (hotter than 100 °C). An exception to this are the bottom of the appliance and the controls.
- Do not place any inflammable materials within a of 0.5 m. of the radiation of the appliance and ventilation grills.
- Due to natural air circulation of the appliance, moisture and volatile components from paint, building materials, floor coverings etc. that haven't yet set, can be drawn through the convection system and can be deposited on cold surfaces as

soot. That is why you should not use the appliance shortly after a renovation.

- The first time the appliance is switched on, Let the fire run on maximum setting for several hours so that the lacquer coating will have an opportunity to set and possible vapours released can be safely removed by ventilation. We advise you to be outside the room as much as possible during this process!
- Please note that:
 - 1 all transport packaging should be removed.
 - 2 children or pets should not be present in the room.

3 Installation requirements

3.1 The fire

- The appliance must be built into an existing or a newly to be constructed false chimney breast.
- In appliances with flexible gas pipes, the gas control valve is mounted to the right side of the fire for safe transport . Unscrew it and mount it at a distance of max. 30 cm behind the access door.
- The receiver which has been attached in a transport holder (see fig. 1.4 A) to the side of control valve bracket, can now be slid onto the top of the control valve bracket. The transport holder can be removed now.

3.2 False Chimney breast

- The false chimney breast must be constructed of an non-combustible material.
- Always ventilate the space above the appliance by means of the grills or a comparable alternative with a minimum air supply of 200 cm².
- For the finish, use special stucco (min. 100°C resistant) or glass fibre wallpaper to prevent discoloration or cracks etc. Recommended drying time: for plaster is a minimum of 24 hours per mm of coat applied.
- The false chimney breast and its construction may not rest on the appliance

3.3 Requirements flue system and outlets

- You should always make use of the materials prescribed by Faber International Ltd. Only by using these materials can Faber International Ltd. guarantee a proper functioning.
- The outside of the concentric flue material can reach a temperature of Approx 150°C. Make sure of proper insulation and protection in case of transit

through combustible wall or ceiling constructions. And observe sufficient distance.

- Make sure that the concentric flue materials are bracketed every 2 metres when they have an extended length, so that the weight of the flue material is not resting on the appliance itself.
- You may never start with a cut-down concentric pipe directly on to the appliance.

3.4 terminals

The flue outlet can end on an external wall or a roof . Check whether the outlet desired by you complies with local requirements concerning good function and ventilation systems .

For a proper functioning the terminal should be at least 0.5 m. away from:

- Corners of the building.
- Roof overhangs and balconies.
- Eaves (with the exception of the roof ridge).

3.5 Existing chimney

You can also connect the appliance to an existing chimney. The existing chimney will function as an air supply and a flexible stainless steel pipe drawn up through the chimney will remove the combustion gas.

The flexible stainless steel pipe of Ø 100 mm should have a CE mark for temperatures up to 600° Celsius.

The chimney should comply with the following requirements:

- The diameter of the flue system must be at least 150x150 mm.
- There should be no more than 1 appliance connected to a flue pipe.
- The chimney must be in good condition
 - No leakage and
 - It should be properly swept.

For more information about connections to existing flue systems, see the manual "connections" .



4 Preparation and Installation instructions

4.1 Gas connection

The gas connection must comply with locally valid standards.

We advise Pipe work from the meter to the appliance must be of adequate size., with near the appliance a gas isolater tap that should always be accessible. Place the gas connection in such a way that this is easily accessible, and that before service, the burner unit can be disconnected at all times.

4.2 Electric connection

If an adapter is used for the power supply, then a wall socket 230VAC - 50Hz must be mounted in the close neighbourhood of the hearth.

4.3 Preparation of the appliance

- Remove the packaging of the appliance . Make sure the gas pipes underneath the appliance are not damaged.
- Clear a safe space to store the frame and the glass.
- Remove the frame , (if necessary) and the glass and take the separately wrapped parts out of the appliance
- Prepare the gas connection to the gas control valve.

4.4 Placing the appliance

Take the installation requirements into account (see chapter 3)

Place the appliance into the proper position and if necessary, adjust the height with the adjustable legs.

Adjusting the height and leveling the hearth with a spirit level.(see fig. 1.5)

- Rough height adjustment:
 - with the extending legs, or the long additional legs.
- Accurate:
 - with the rotating adjustable legs.

4.5 Mounting the smoke emission outlet materials

- In case of a wall or roof terminal, the hole must be at least 5 mm bigger than the diameter of the flue material.
- Horizontal parts must be installed at a (3 degree) slope up away the appliance.
- Build up the system from the appliance. If this is not possible, you should make use of a adjustable pipe .
- For fitting the system a ½ metre cut-down pipe should be used. Make sure the inner pipe is always 2 cm longer than the outer pipe. Wall and roof terminal are also shortened. These parts must be secured with a self tapping screw.
- Do not insulate but ventilate bild-in flue material (approx.100cm²)

4.6 Building a chimney breast.

Before constructing the chimney breast we advise you to perform a function test with the appliance as described in chapter 7 "checking the installation"

4.7 Chimney breast

- Construct the chimney breast from non-combustible material in combination with metal profiles or brickwork / aerated concrete bricks.
- Take the grills and the service panel (see fig.1.1 and 1.2)into account. Place a protective shield made of non- combustible material above the grills (see fig1.1.A) .
- During the construction, regularly test whether rotating parts are not impeded and/or if the glass can be removed.
- Always use a lintel if the chimney breast is constructed of brickwork. These should not be placed directly onto the hearth.
- The appliance can built-in in three different ways. The total wall thickness is dependent on the manner of construction. (consult the dimensional drawing):
 1. Frames on both sides: 384 mm =192+192
 2. Frameless on both sides: maximum 520 mm =(50+210)+(210+50)
 3. Combination of both: maximum 452 mm = 192+(210+50)

4.8 Glance Frameless

Take the following points into account in connection with the removal of the glass.

- Make use of the guide-line (see fig. 2.3 A). Build straight onto this. The guide-line will indicate the minimum window aperture. Never build within this window aperture! (see 2.3)
- During construction , check regularly whether the slides (see fig. 2.1 B) can be moved to and fro and check the distance between the chimney breast and the glass. The distance should be at least 12 mm.
- The depth of the recess should be no more than 50 mm.

4.9 Glance Framed

Take the following points into account in connection with the placing of the frame:

- Make use of the guide-line (see fig.2.5 and 2.6). These will indicate how far the appliance extends out the wall. Never build in front of these guide-lines
- Keep a free rotating space (110 mm) at the bottom of the hearth.
- Hang the frame to the suspension strip (see fig.2.5).

5 removing the glass

- Place the suction discs onto the glass
- Slide the cover ledges (see fig. 2.1 B) outwards. On the right side a lever (see fig.2.1) will be visible. Unscrew this.
- Due to spring pressure the lever will come forwards (if necessary, pull it onwards). The glass will no longer be clamped tightly.
- Slide the glass upwards, so that the bottom edge is released. Gradually move the glass forwards and downwards. (See fig 2.2)

To replace the glass repeat the process in reverse order.

Remove all fingerprints from the glass, these will be burned into it once the hearth is used.



6 Placing the decorative material

It is not allowed to add different or more materials to the combustion chamber.

Always keep the pilot burner free from decorative material!

Do not toss all the decorative material onto the burner all at once, it can be obstructed by dust particles.

6.1 Imitation logs

- Place a number of the chips onto the burner and on the cover plate
- Place the imitation logs according to instructions. (see fig.3.1 or imitation logs instruction card supplied)
- Divide the remainder of the chips over the burner and the cover plate . Avoid a thick layer onto the burner, this has a negative effect on the fire image.
- Ignite the pilot and main burner according to the instructions in the user's manual. Assess whether the flame division is correct. If necessary, move the chips until there is a proper division of flames.
- Place the glass and check the fire image.

6.2 Pebbles

- Place the pebbles on the burner and the cover plate (see fig. 3.2 or imitation logs instruction card supplied). Avoid a double layer; this has a negative effect on the fire image.
- Place the glass and check the fire image.



7 Checking the installation.

7.1 Checking the ignition of the pilot burner, main burner.

Start the pilot and main burner according to the instructions in the user's manual.

- Check whether the pilot light is properly positioned above the main burner and is not covered by chips, an imitation log or pebbles.
- Check the ignition of the main burner at full mark or low mark.
(the ignition should take place quickly and easily).

7.2 Checking for gas leakage.

Check all connections and joins for possible gas leaks by means of a gas leak detector or spray

7.3 Checking the burner pressure and the pre-pressure

Check whether the burner pressure and the inlet pressure measured agree with the data indicated on the registration plate

Measuring the inlet-pressure:

- Turn off the gas control tap.
- Open the pressure gauge nipple B (see figure 1.3) a few turns and connect a pressure gauge hose to the gas control valve.
- Carry out this measurement when the appliance is on at full gas mark and when it is on the pilot light.
- If the inlet pressure is too high you are not permitted to connect the appliance.

Measuring the burner pressure:

Only perform this measurement if the inlet-pressure is correct.

- Open the pressure gauge nipple A (see fig.1.3.) a few turns and connect a pressure gauge hose to the gas control valve.
- The pressure must agree with the value indicated on the registration plate. In case of deviations, get in touch with the manufacturer.

* Close the pressure gauge nipples and check these for gas leaks.



7.4 Checking the flame picture.

Allow the appliance to burn for at least 20 minutes at full and then check the flame picture for:

1. Distribution of the flames
2. Colour of the flames

If either one or both points are unacceptable, then check:

- The positioning of the imitation logs and/or the quantity of pebbles or chips on the burner.
- The connections of the Flue materials for leakage (in case of blue flames)
- Whether the correct flue restrictor has been mounted
- The outlet .
 - Wall terminal is installed correctly
 - Roof terminal is fitted and sited correctly
- The flue system is correctly calculated

8 Instructing the client

- Recommend that the appliance be serviced annually by a competent person in order to guarantee a safe use and a long lifespan.
- Advise and instruct the client about maintenance and cleaning of the glass. Emphasize the risk of burning in fingerprints.
- Instruct the client about the operation of the appliance and the remote control unit, including the replacement of the batteries and adjusting the receiver for initial use.
- Hand over to the client:
 - Installation manual
 - User's manual
 - Imitation logs instruction card
 - Suction lifters



9 Annual maintenance

9.1 Service and cleaning:

- Check and clean if necessary after checking:
 - The pilot light
 - The burner (in an LPG flat burner replace the burner sheet)
 - The combustion chamber
 - The glass
 - The logs for possible fractures
 - The outlet

9.2 Replace:

- (in an LPG flat burner replace the burner sheet)
- If necessary the chips/embers.

9.3 Cleaning the glass

Most of the deposits can be removed with a dry cloth. You can use ceramic hob cleaner to clean the glass.

Note: prevent fingerprints on the glass. these will be burned into it once the appliance is used and cannot be removed anymore!

Carry-out the check-up according to the instructions in chapter 7 "checking the installation"

10 Conversion to a different type of gas (e.g. propane)

This can only be done by installing the proper burner unit. for this purpose get in touch with your supplier.

Always mention the type and serial number of the appliance when ordering.



11 Calculation of flue system

The possibilities for the lengths of flue pipes and the possible restrictors have been recorded in a table (see chapter 12) This table works with a vertical and a horizontal length.

- To define the vertical length all lengths of flue pipes in a vertical direction should be added up.
 - The roof terminal always counts as 1 metre.
- To define the horizontal length all lengths of flue pipes in a horizontal direction should be added up.
 - every 90° bend in the horizontal part counts as 2 metres.
 - every 45° bend in the horizontal part counts as 1 metre.
 - Turns from vertical to horizontal or vice versa are not reckoned in the calculation.
 - The wall terminal always counts as 1 metre.

If there is transit under 45° then the real vertical and horizontal lengths should be calculated.

11.1 Points of particular interest:

- The maximum chimney length is 12 metres.
- You can never start with a 90° or 45° bend from the appliance.
- You should always start with 1 metre vertical if the horizontal transit is more than 1 metre.
- You should never start with a cut-down pipe from the appliance.

11.2 Sample computations

Sample calculation 1

Count the horizontal lengths

Flue pipe lengths	$C+E = 1 + 1$	2 m
Bend	$D = 1 \times 2$	2 m
Total		4 m

Count the vertical lengths

Flue pipe length A	1 m	
Roof terminal G		1 m
Total	2 m	

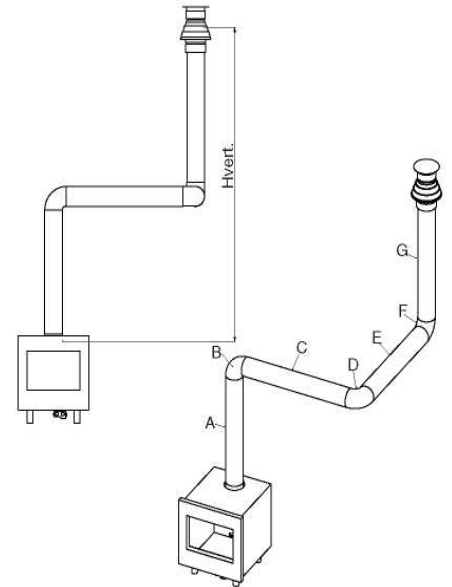

Sample calculation 2

Count the horizontal lengths

Flue pipe lengths	$J + L = 0,5 + 0,5$	1 m
Bends	$K + M = 2 + 2$	4 m
Wall terminal		1 m
Total horizontal length		6 m

Count the vertical lengths

Flue pipe length H	1 m	
Total	1 m	

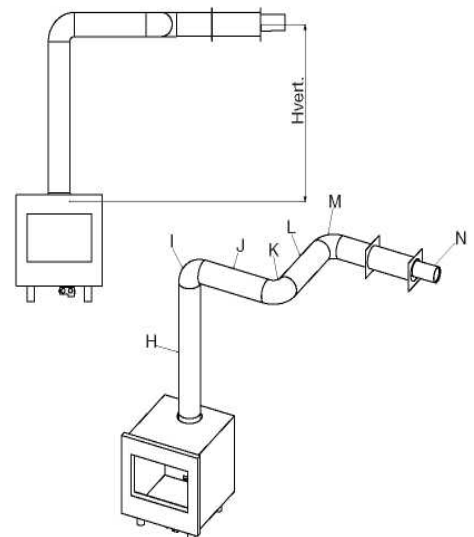

12 Table

Find the correct vertical and horizontal lengths in the table.

In case of an "x", or if the values are outside the table, the combination is not permitted.

The value found indicates the width of the restrictor to be placed ("0" means no restrictor should be placed).

Generally a 30mm restrictor is pre-installed

		Horizontaal						
		0	1	2	3	4	5	6
Verticaal	0	X	X	X	X	X	X	X
	0.5	X	X	X	X	X	X	X
	1	0	0	0	X	X	X	X
	1.5	30	30	0	0	X	X	X
	2	30	30	30	0	0	0	0
	3	40	30	30	30	0	0	0
	4	40	40	30	30	30	0	0
	5	50	40	40	30	30	30	0
	6	50	50	40	40	30	30	0
	7	50	50	50	40	40	40	X
	8	60	50	50	40	40	X	X
	9	60	60	50	50	X	X	X
	10	65	60	60	X	X	X	X
	11	65	65	X	X	X	X	X
12	65	X	X	X	X	X	X	

13 Technical data

Gascat.		II2H3+	II2H3+	II 2H3+
Type appliance		C11 C31	C11 C31	C11 of C31
Reference gas		G20	G30	G31
Input Nett	kW	9.6	8.3	8.3
Efficiency class		2	2	2
NOx class		5	5	5
inlet-pressure	mbar	20	30	37
Gas rate at 15°C and 1013 mbar	l/h	935	270	341
Gas rate at 15°C and 1013 mbar	gr/h		680	640
Burner pressure at full mark	mbar	12	21	26
Injector main burner	mm	800	280	280
Reduced input restraint	mm	2.1	1.1	1.1
Pilot assembly		SIT 145-19	SIT 145-19	SIT 145-19
Code		Nr.30	Nr.23	Nr.23
Diameter inlet / outlet	mm	150/100	150/100	150/100
Gas control valve		GV60	GV60	GV60
Gas connection		3/8"	3/8"	3/8"
Electrical connection	V	220	220	220
Batteries receiver	V	4x1.5AA	4x1.5AA	4x1.5AA
Batteries sender	V	9	9	9

14 Dimension of the appliance

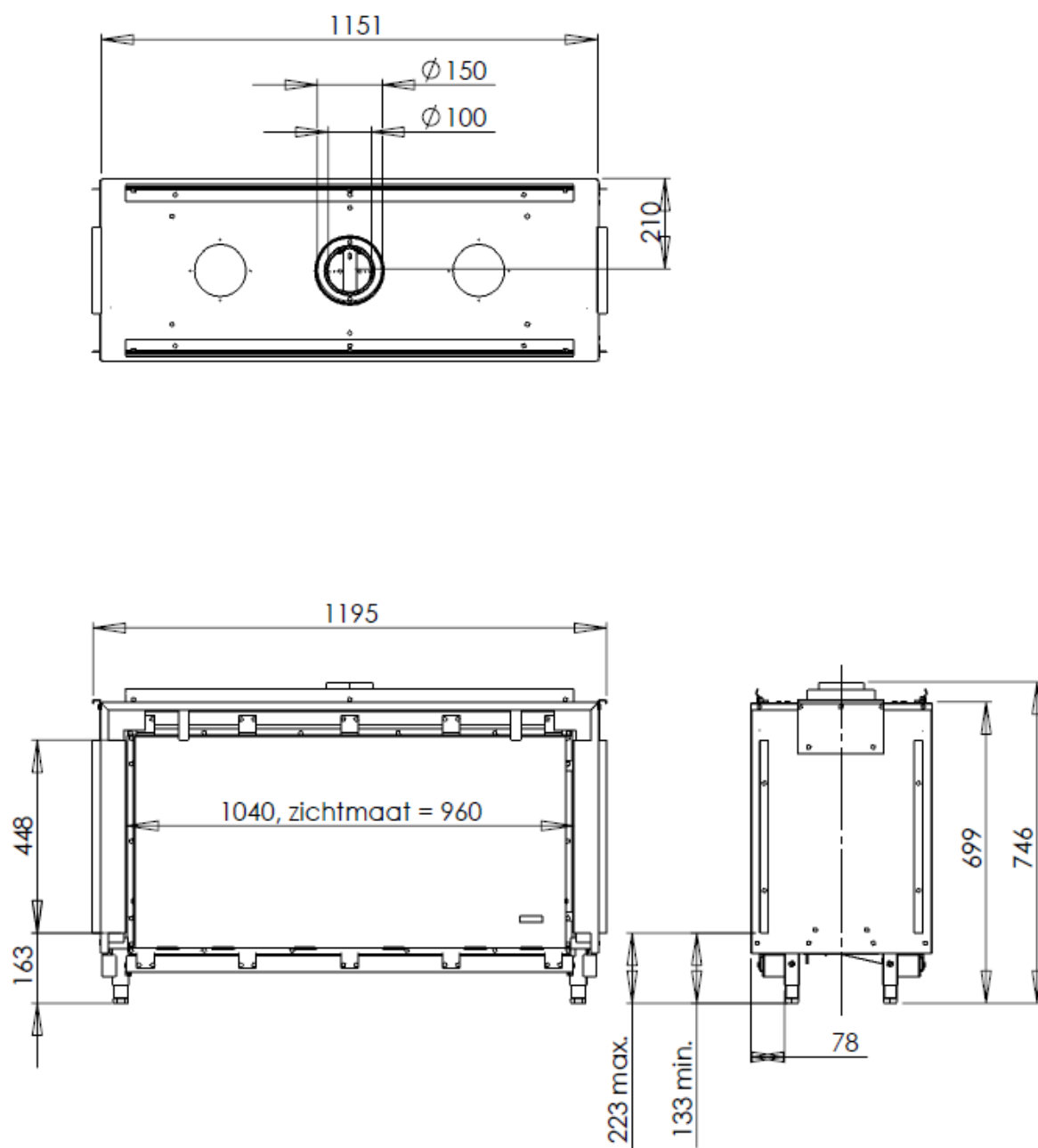

15 Dimension of the appliance with frame

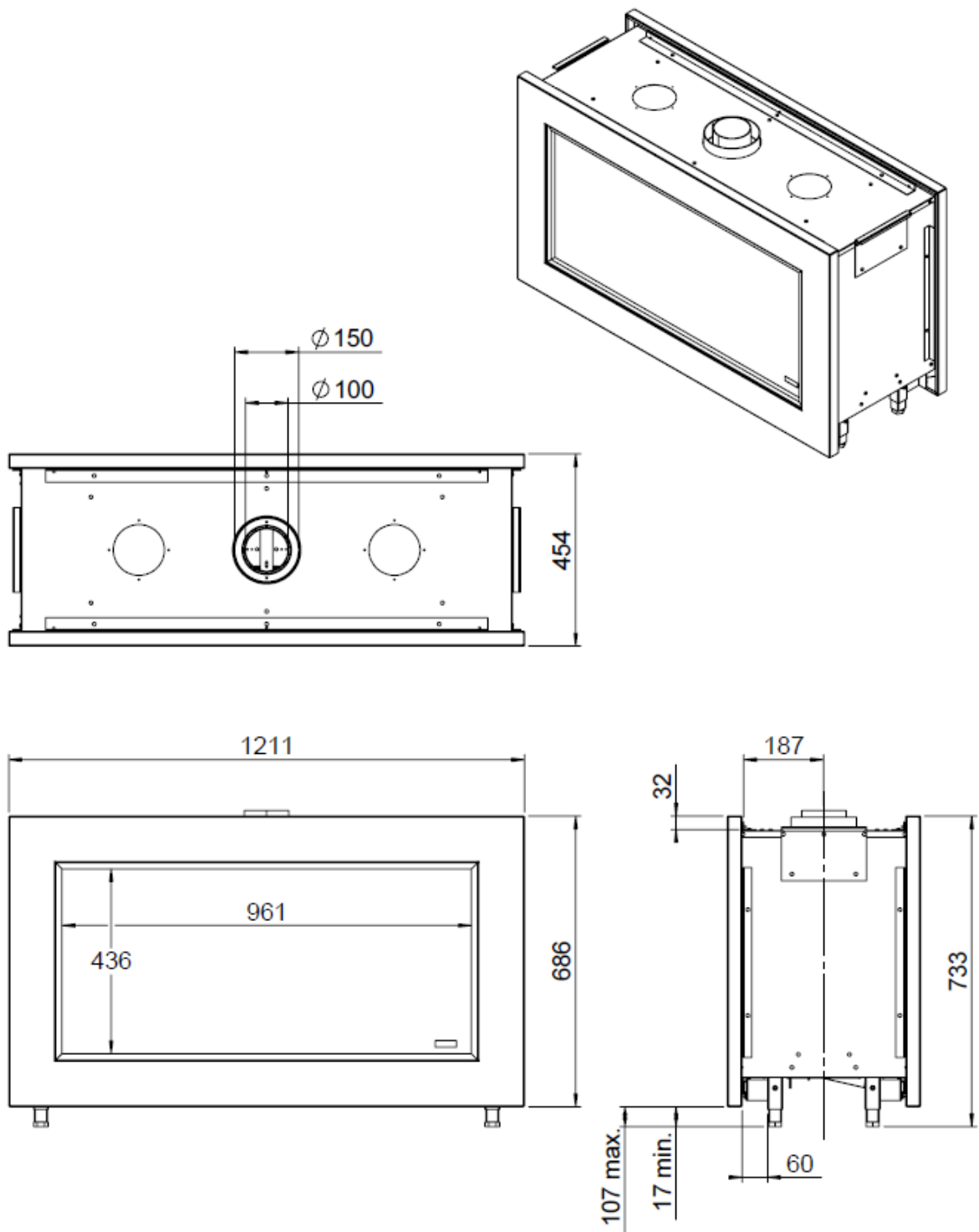

16 Ventilation Grills

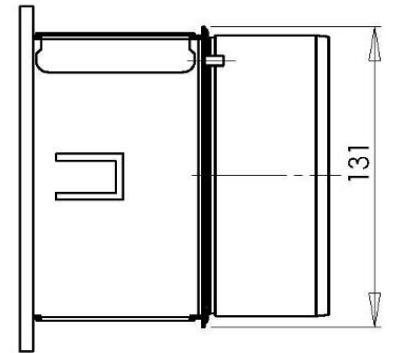
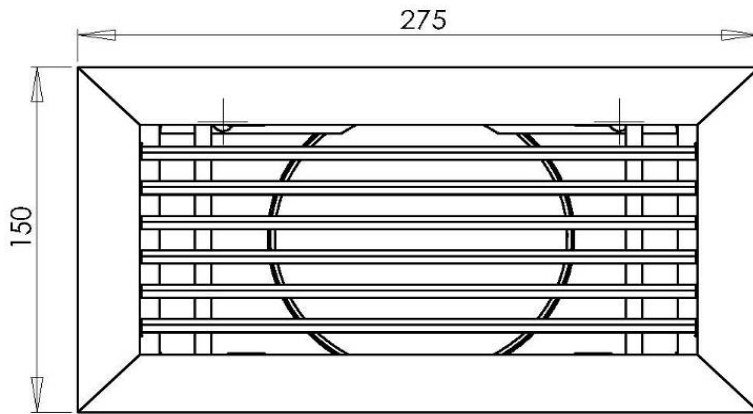
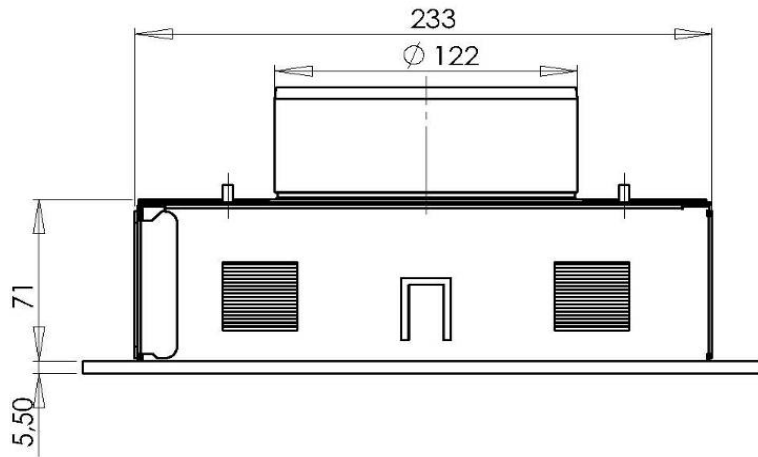

17 Dimension Service Hatch

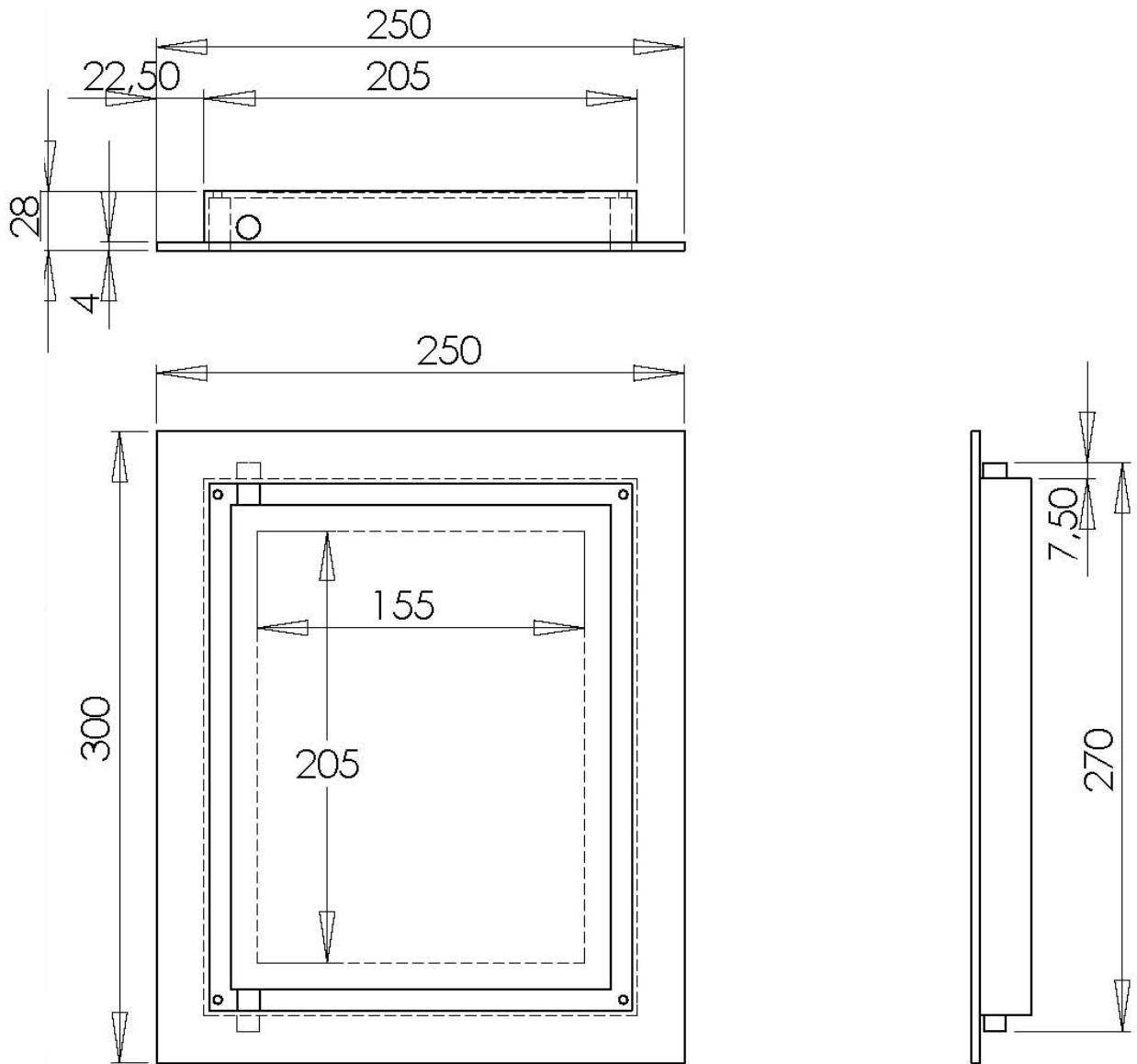





www.faber.nl - info@faber.nl
Saturnus 8 NL - 8448 CC Heerenveen
Postbus 219 NL - 8440 AE Heerenveen
T. +31(0)513 656500
F. +31(0)513 656501